

## Specification Sheet

### Model # : LF813D 1/2" PC X 1/2" FNPT Elbow Drop Ear

1. Construction: Forged Lead Free and Low Lead Brass
2. Working Pressure 200 PSI Max
3. Temperature Rating 200 °F Max
4. Tested and certified by IAPMO 200 °F/ 200 PSI

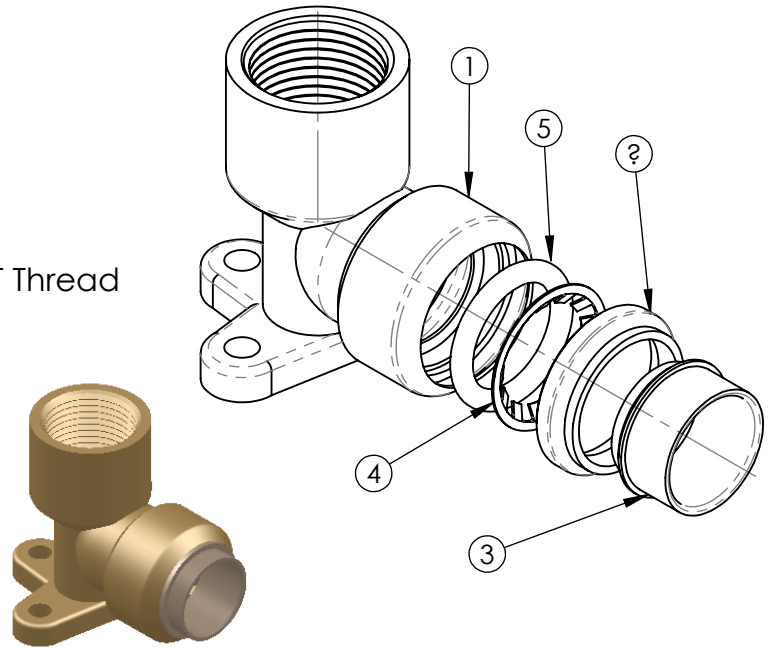
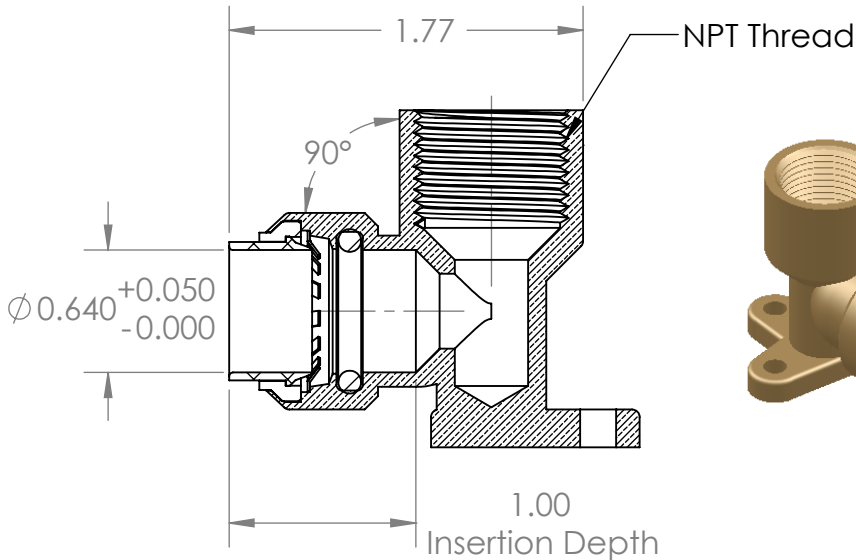

#### Approved Applications:

- Plumbing
- Heating
- Irrigation
- Underground
- Hydronic Heating
- Behind Walls without Access Panel

#### Features:

- Lead Free Compliant Materials
- 75 Year Warranty
- Compatible with Copper, CPVC, PEX & PE-RT
- Push to Connect
- Full Flow
- Removable
- Re-usable
- Replaceable O-Ring Seal Design

#### FORCES FOR MECHANICAL SEPARATION TEST

| NOMINAL SIZE |         | LONGITUDINAL (PULL) TEST |        |
|--------------|---------|--------------------------|--------|
| Inches       | mm      | Lbf                      | N      |
| 3/8 or <     | 10 or < | 100.0                    | 444.8  |
| 1/2          | 13      | 150.0                    | 667    |
| 3/4          | 19      | 275.0                    | 1223.2 |
| 1            | 25      | 475.0                    | 2112.8 |
| 1-1/4        | 32      | 700.0                    | 3113.6 |
| 1-1/2        | 38      | 1000.0                   | 4446.0 |
| 2            | 51      | 1675.0                   | 7445.4 |

#### MATERIALS & SPECIFICATIONS

| NO. | COMPONENT   | MATERIAL        |
|-----|-------------|-----------------|
| 1   | Body        | Lead Free Brass |
| 2   | Seat Ring   | POM             |
| 3   | Push Ring   | POM             |
| 4   | Grip Ring   | Stainless Steel |
| 5   | O-Ring Seal | EPDM70          |
| 6   |             |                 |

#### Certifications

- cUPC
- ASSE1061 - 2011
- NSF/ANSI 61
- IAPMO Listed
- Lead Law Compliant

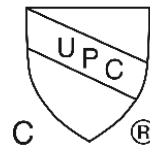

\*A ProBite hi-flow tube stiffener should be used when connecting to PEX tube.

#### PROPRIETARY AND CONFIDENTIAL

THE INFORMATION CONTAINED IN THIS DRAWING IS THE SOLE INTELLECTUAL PROPERTY AND COPYRIGHT OF QUICK FITTING INC. ANY TRANSMISSION, DUPLICATION OR REPRODUCTION IN PART OR WHOLE WITHOUT THE WRITTEN CONSENT OF QUICK FITTING INC. IS PROHIBITED.